

eCANTER 4S15e

LEFT-HAND DRIVE

MODEL / VEHICLE TYPE

	4S15e			
Cab type / crew	Standard, single cab / 3			
Battery variant	S			M
Model variant	84000211	84000311	84000511	84001511
FUSO model code	FEAVKBLCSEU3	FEAVKCLCSEU3	FEAVKELCSEU3	FEAVKELDSEU3

DIMENSIONS (MM)

Wheelbase	2500	2800	3400	
Overall length	4766	5044	5788	
Cab length	1510			
Width overall	1869			
Cab width	1798			
Height overall	2120–2238	2150–2238	2148–2238	2141–2229
Track width	Front / rear		1390 / 1435	
Frame height (at end of frame)	150			
Ground clearance	260			250
Cab to rear axle	1975	2278	2781	
Cab to end of frame	3128	3478	4278	
Maximum body length ²⁾	3500	3995	4985	
Frame width	701			
Front overhang	993			
Rear overhang	1145	1195	1395	
Front axle to front of body	625			
Recommended distance cab to body	100			

WEIGHTS (KG)

Empty weight ¹⁾		2515	2525	2550	3025
	Front / rear	1408 / 1107	1414 / 1111	1428 / 1122	1603 / 1422
Minimum vehicle weight		2705	2715	2740	3215
Gross vehicle weight		4250			
Axle loads ¹⁾	Front / rear	2600 / 4500			
Chassis load bearing capacity ²⁾		1735	1725	1700	1225

DRIVING PERFORMANCE AND AGILITY

Maximum speed	km/h	89			
Minimum turning circle (m)	Kerb to kerb	9.8	10.8	12.8	
	Wall to wall	10.8	12.0	14.0	

¹⁾ The weight refers to the base vehicle (European series, including high voltage battery, tyre sealant, tools and driver with 75 kg) without optional equipment. If any optional equipment is added, the weight changes accordingly.

²⁾ Calculated maximum value which should be checked depending on the body and application. Subject to change without notice. All data is approximate.

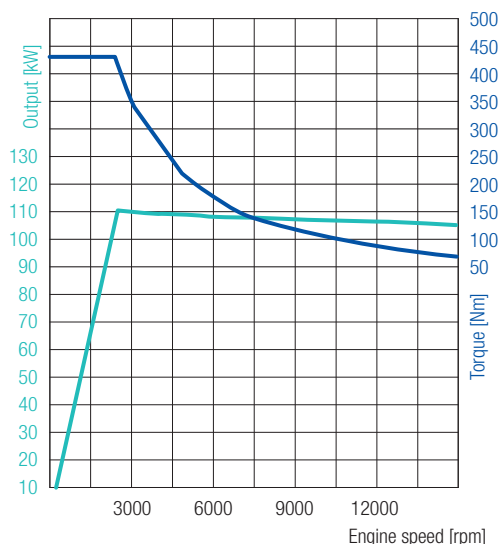
110 kW (150 hp)
430 Nm

eCANTER 4S15e

LEFT-HAND DRIVE

ELECTRIC DRIVE

Type	S40		
Peak output / continuous output	110 kW (150 hp) / 85 kW (116 hp)		
Maximum torque / continous torque	430 Nm / 250 Nm		
PTO (optional)	Type	mPTO with pump connection	mPTO with pulley
	Maximum torque	222 Nm at 2000 rpm	64 Nm at 7000 rpm
	Continuous power / torque	17 kW / 166 Nm, maximum 2000 rpm	17 kW / 46 Nm, maximum 7000 rpm
	Gear ratio	0.286	–

HIGH VOLTAGE BATTERY

Battery variant	S		M
Capacity usable / installed	kWh	39 / 41	78 / 82
Weight ³⁾	kg	475	950
Range ⁴⁾	km	70	140

CHARGING

Connection type / variants	CCS TYP 2 (AC / DC)		
Maximum charging capacity AC / DC	kW	11 / 70	22 / 104
Maximum charging time AC ⁵⁾	0–100 % h:min	4:12	4:54
Maximum charging time DC ⁵⁾	20–80 % h:min	0:24	0:26
	5–90 % h:min	0:36	0:44

POWERTRAIN

Climbing ability	20 %
------------------	------

CHASSIS

Front axle / rear axle	Independent suspension / E-axle		
Tyres	205/75 R 17.5		
Wheel	17.5 x 6.00 - 115		
Steering	Left-hand drive	Recirculating ball steering with power assist, tilting telescopic steering column with steering-wheel lock	
Brake	Service brake	Hydraulic with vacuum power assist, dual-circuit with load-dependent brake proportioning valve at rear wheels	
	Front / rear	Disc brake (293 x 40 mm / 314 x 35 mm)	
	Parking brake	Electromechanical brake caliper on rear disc brake	
Suspension	Front / rear	Coil springs with shock absorber / Semi-elliptic leaf springs with shock absorber and stabilizer	
Frame	Type	Ladder-type frame with reinforcements and crossmembers	
Electrical system	Low voltage batteries	Series 12 V (80 Ah) / optional 24 V (80 + 60 Ah)	

3) The specified weight includes both the battery(ies) with 325 kg each and the peripheral installations (cabling, temperature control, protection, etc.).

4) The range depends on various factors such as load, driving style, topography, ambient temperature or weather, battery age, vehicle equipment. The actual range may vary.

The given values for the range were tested with a box body, a load of 50% of the payload, an ambient temperature of 20 °C and an average battery age.

5) The charging time depends on various factors such as the charging capacity of the vehicle and charging station, the battery's state of charge, ambient and battery temperature.

The given values for the charging time were tested under optimum ambient temperature of 20 °C.

The illustrations may contain accessories and items of optional equipment which are not part of the standard specification. The data sheet may contain product types and support services not available in certain countries.

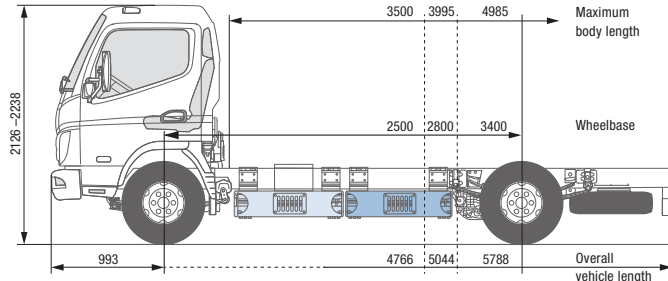
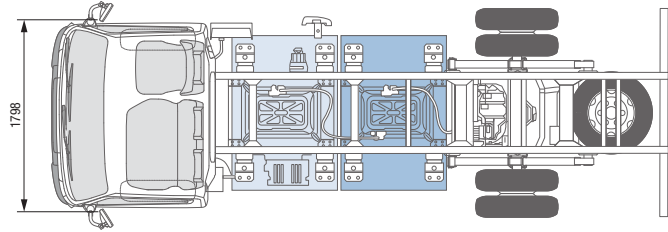

eCANTER 4S15e RIGHT-HAND DRIVE

MODEL / VEHICLE TYPE

	4S15e			
Cab type / crew	Standard, single cab / 3			
Battery variant	S			M
Model variant	84000221	84000321	84000521	84001521
FUSO model code	FEAVKBRCEU3	FEAVKRCSEU3	FEAVKRCSEU3	FEAVKERDSEU3

DIMENSIONS (MM)

Wheelbase	2500	2800	3400	
Overall length	4766	5044	5788	
Cab length	1510			
Width overall	1869			
Cab width	1798			
Height overall	2120–2238	2150–2238	2148–2238	2141–2229
Track width	Front / rear		1390 / 1435	
Frame height (at end of frame)	150			
Ground clearance	260			250
Cab to rear axle	1975	2278	2781	
Cab to end of frame	3128	3478	4278	
Maximum body length ²⁾	3500	3995	4985	
Frame width	701			
Front overhang	993			
Rear overhang	1145	1195	1395	
Front axle to front of body	625			
Recommended distance cab to body	100			

WEIGHTS (KG)

Empty weight ¹⁾		2515	2525	2550	3025
	Front / rear	1408 / 1107	1414 / 1111	1428 / 1122	1603 / 1422
Minimum vehicle weight		2705	2715	2740	3215
Gross vehicle weight		4250			
Axle loads ¹⁾	Front / rear	2600 / 4500			
Chassis load bearing capacity ²⁾		1735	1725	1700	1225

DRIVING PERFORMANCE AND AGILITY

Maximum speed	km/h	89			
Minimum turning circle (m)	Kerb to kerb	9.8	10.8	12.8	
	Wall to wall	10.8	12.0	14.0	

¹⁾ The weight refers to the base vehicle (European series, including high voltage battery, tyre sealant, tools and driver with 75 kg) without optional equipment. If any optional equipment is added, the weight changes accordingly.

²⁾ Calculated maximum value which should be checked depending on the body and application. Subject to change without notice. All data is approximate.

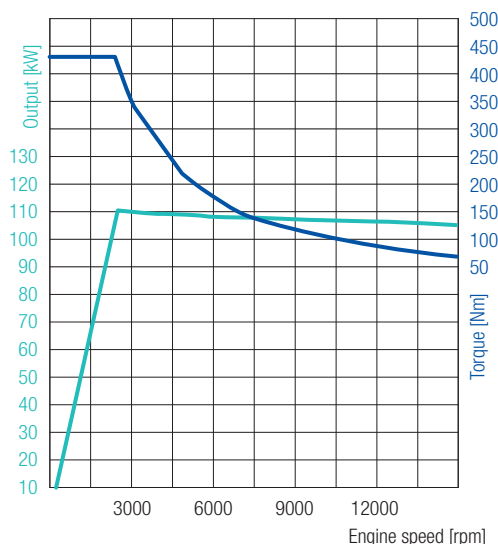
110 kW (150 hp)
430 Nm

eCANTER 4S15e

RIGHT-HAND DRIVE

ELECTRIC DRIVE

Type	S40		
Peak output / continuous output	110 kW (150 hp) / 85 kW (116 hp)		
Maximum torque / continuous torque	430 Nm / 250 Nm		
PTO (optional)	Type	mPTO with pump connection	mPTO with pulley
	Maximum torque	222 Nm at 2000 rpm	64 Nm at 7000 rpm
	Continuous power / torque	17 kW / 166 Nm, maximum 2000 rpm	17 kW / 46 Nm, maximum 7000 rpm
	Gear ratio	0.286	–

HIGH VOLTAGE BATTERY

Battery variant		S	M
Capacity usable / installed	kWh	39 / 41	78 / 82
Weight ³⁾	kg	475	950
Range ⁴⁾	km	70	140

CHARGING

Connection type / variants	CCS TYP 2 (AC / DC)		
Maximum charging capacity AC / DC	kW	11 / 70	22 / 104
Maximum charging time AC ⁵⁾	0–100 % h:min	4:12	4:54
Maximum charging time DC ⁵⁾	20–80 % h:min	0:24	0:26
	5–90 % h:min	0:36	0:44

POWERTRAIN

Climbing ability	20 %
------------------	------

CHASSIS

Front axle / rear axle	Independent suspension / E-axle		
Tyres	205/75 R 17.5		
Wheel	17.5 x 6.00 - 115		
Steering	Right-hand drive	Recirculating ball steering with power assist, tilting telescopic steering column with steering-wheel lock	
Brake	Service brake	Hydraulic with vacuum power assist, dual-circuit with load-dependent brake proportioning valve at rear wheels	
	Front / rear	Disc brake (293 x 40 mm / 314 x 35 mm)	
	Parking brake	Electromechanical brake caliper on rear disc brake	
Suspension	Front / rear	Coil springs with shock absorber / Semi-elliptic leaf springs with shock absorber and stabilizer	
Frame	Type	Ladder-type frame with reinforcements and crossmembers	
Electrical system	Low voltage batteries	Series 12 V (80 Ah) / optional 24 V (80 + 60 Ah)	

3) The specified weight includes both the battery(ies) with 325 kg each and the peripheral installations (cabling, temperature control, protection, etc.).

4) The range depends on various factors such as load, driving style, topography, ambient temperature or weather, battery age, vehicle equipment. The actual range may vary.

The given values for the range were tested with a box body, a load of 50% of the payload, an ambient temperature of 20 °C and an average battery age.

5) The charging time depends on various factors such as the charging capacity of the vehicle and charging station, the battery's state of charge, ambient and battery temperature.

The given values for the charging time were tested under optimum ambient temperature of 20 °C.

The illustrations may contain accessories and items of optional equipment which are not part of the standard specification. The data sheet may contain product types and support services not available in certain countries.

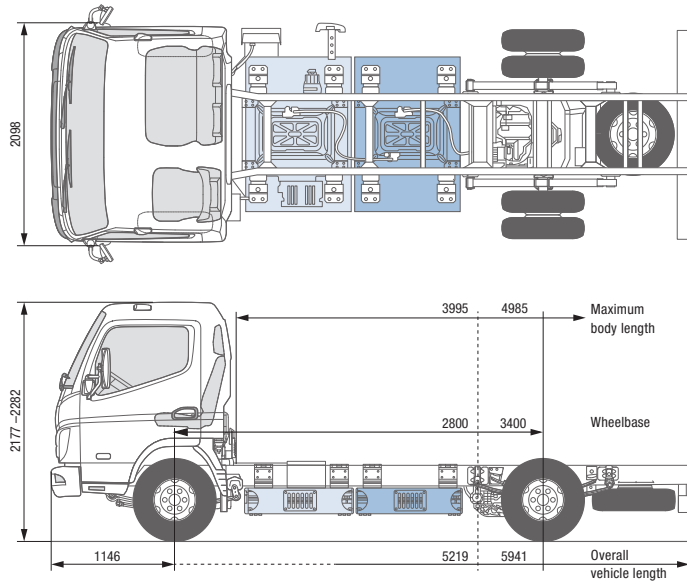

eCANTER 4C15e LEFT-HAND DRIVE

MODEL / VEHICLE TYPE

	4C15e		
Cab type / crew	Comfort, single cab / 3		
Battery variant	S		M
Model variant	84002311	84002511	84003511
FUSO model code	FEBVKLCSEU3	FEBVKELCSEU3	FEBVKELDSEU3

DIMENSIONS (MM)

Wheelbase		2800	3400
Overall length		5219	5941
Cab length			1631
Width overall			1924
Cab width			2098
Height overall		2186–2282	2148–2282
Track width	Front / rear		1655 / 1490
Frame height (at end of frame)			152
Ground clearance		260	265
Cab to rear axle		2275	2875
Cab to end of frame		3510	4310
Maximum body length ²⁾		3995	4985
Frame width			752
Front overhang			1146
Rear overhang		1195	1395
Front axle to front of body			625
Recommended distance cab to body			100

WEIGHTS (KG)

Empty weight ¹⁾		2670	2690	3160
	Front / rear	1575 / 1095	1587 / 1103	1675 / 1485
Minimum vehicle weight		2860	2880	3350
Gross vehicle weight			4250	
Axle loads ¹⁾	Front / rear		2600 / 4500	
Chassis load bearing capacity ²⁾		1580	1560	1090

DRIVING PERFORMANCE AND AGILITY

Maximum speed	km/h		89
Minimum turning circle (m)	Kerb to kerb	10.2	12.0
	Wall to wall	11.6	13.4

¹⁾ The weight refers to the base vehicle (European series, including high voltage battery, tyre sealant, tools and driver with 75 kg) without optional equipment. If any optional equipment is added, the weight changes accordingly.

²⁾ Calculated maximum value which should be checked depending on the body and application. Subject to change without notice. All data is approximate.

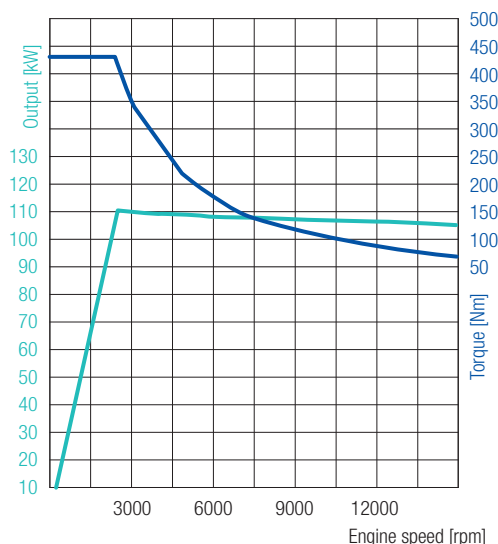

110 kW (150 hp)
430 Nm

eCANTER 4C15e

LEFT-HAND DRIVE

ELECTRIC DRIVE

Type	S40		
Peak output / continuous output	110 kW (150 hp) / 85 kW (116 hp)		
Maximum torque / continuous torque	430 Nm / 250 Nm		
PTO (optional)	Type	mPTO with pump connection	mPTO with pulley
	Maximum torque	222 Nm at 2000 rpm	64 Nm at 7000 rpm
	Continuous power / torque	17 kW / 166 Nm, maximum 2000 rpm	17 kW / 46 Nm, maximum 7000 rpm
	Gear ratio	0.286	–

HIGH VOLTAGE BATTERY

Battery variant	S		M
Capacity usable / installed	kWh	39 / 41	78 / 82
Weight ³⁾	kg	470	940
Range ⁴⁾	km	70	140

CHARGING

Connection type / variants	CCS TYP 2 (AC / DC)		
Maximum charging capacity AC / DC	kW	11 / 70	22 / 104
Maximum charging time AC ⁵⁾	0–100 %	h:min	4:12
Maximum charging time DC ⁵⁾	20–80 %	h:min	0:24
	5–90 %	h:min	0:36

POWERTRAIN

Climbing ability	20 %
------------------	------

CHASSIS

Front axle / rear axle	Independent suspension / E-axle	
Tyres	205/75 R 17.5	
Wheel	17.5 x 6.00 - 115	
Steering	Left-hand drive	Recirculating ball steering with power assist, tilting telescopic steering column with steering-wheel lock
Brake	Service brake	Hydraulic with vacuum power assist, dual-circuit with load-dependent brake proportioning valve at rear wheels
	Front / rear	Disc brake (293 x 40 mm / 314 x 35 mm)
	Parking brake	Electromechanical brake caliper on rear disc brake
Suspension	Front / rear	Coil springs with shock absorber / Semi-elliptic leaf springs with shock absorber and stabilizer
Frame	Type	Ladder-type frame with reinforcements and crossmembers
Electrical system	Low voltage batteries	Series 12 V (80 Ah) / optional 24 V (80 + 60 Ah)

3) The specified weight includes both the battery(ies) with 325 kg each and the peripheral installations (cabling, temperature control, protection, etc.).

4) The range depends on various factors such as load, driving style, topography, ambient temperature or weather, battery age, vehicle equipment. The actual range may vary.

The given values for the range were tested with a box body, a load of 50% of the payload, an ambient temperature of 20 °C and an average battery age.

5) The charging time depends on various factors such as the charging capacity of the vehicle and charging station, the battery's state of charge, ambient and battery temperature.

The given values for the charging time were tested under optimum ambient temperature of 20 °C.

The illustrations may contain accessories and items of optional equipment which are not part of the standard specification. The data sheet may contain product types and support services not available in certain countries.

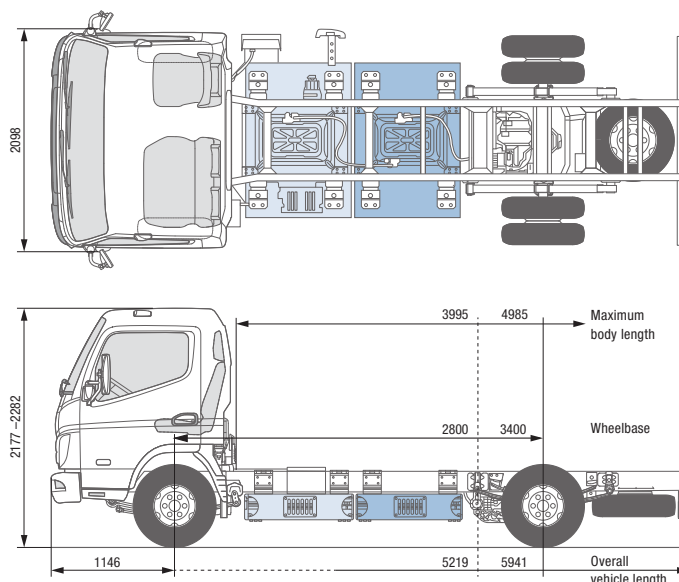

eCANTER 4C15e RIGHT-HAND DRIVE

MODEL / VEHICLE TYPE

	4C15e		
Cab type / crew	Comfort, single cab / 3		
Battery variant	S		M
Model variant	84002321	84002521	84003521
FUSO model code	FEBVKCRCSEU3	FEBVKERCSEU3	FEBVKERDSEU3

DIMENSIONS (MM)

Wheelbase	2800	3400	
Overall length	5219	5941	
Cab length		1631	
Width overall		1924	
Cab width		2098	
Height overall	2186–2282	2148–2282	2177–2273
Track width	Front / rear	1655 / 1490	
Frame height (at end of frame)		152	
Ground clearance	260		265
Cab to rear axle	2275		2875
Cab to end of frame	3510		4310
Maximum body length ²⁾	3995		4985
Frame width		752	
Front overhang		1146	
Rear overhang	1195		1395
Front axle to front of body		625	
Recommended distance cab to body		100	

WEIGHTS (KG)

Empty weight ¹⁾		2670	2690	3160
	Front / rear	1575 / 1095	1587 / 1103	1675 / 1485
Minimum vehicle weight		2860	2880	3350
Gross vehicle weight			4250	
Axle loads ¹⁾	Front / rear		2600 / 4500	
Chassis load bearing capacity ²⁾		1580	1560	1090

DRIVING PERFORMANCE AND AGILITY

Maximum speed	km/h	89	
Minimum turning circle (m)	Kerb to kerb	10.2	12.0
	Wall to wall	11.6	13.4

¹⁾ The weight refers to the base vehicle (European series, including high voltage battery, tyre sealant, tools and driver with 75 kg) without optional equipment. If any optional equipment is added, the weight changes accordingly.

²⁾ Calculated maximum value which should be checked depending on the body and application. Subject to change without notice. All data is approximate.

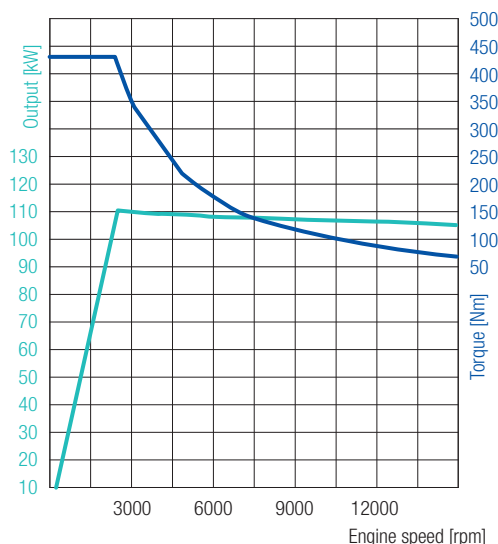
110 kW (150 hp)
430 Nm

eCANTER 4C15e

RIGHT-HAND DRIVE

ELECTRIC DRIVE

Type	S40		
Peak output / continuous output	110 kW (150 hp) / 85 kW (116 hp)		
Maximum torque / continuous torque	430 Nm / 250 Nm		
PTO (optional)	Type	mPTO with pump connection	mPTO with pulley
	Maximum torque	222 Nm at 2000 rpm	64 Nm at 7000 rpm
	Continuous power / torque	17 kW / 166 Nm, maximum 2000 rpm	17 kW / 46 Nm, maximum 7000 rpm
	Gear ratio	0.286	–

HIGH VOLTAGE BATTERY

Battery variant	S		M
Capacity usable / installed	kWh	39 / 41	78 / 82
Weight ³⁾	kg	470	940
Range ⁴⁾	km	70	140

CHARGING

Connection type / variants	CCS TYP 2 (AC / DC)		
Maximum charging capacity AC / DC	kW	11 / 70	22 / 104
Maximum charging time AC ⁵⁾	0–100 %	h:min	4:12
Maximum charging time DC ⁵⁾	20–80 %	h:min	0:26
	5–90 %	h:min	0:36

POWERTRAIN

Climbing ability	20 %
------------------	------

CHASSIS

Front axle / rear axle	Independent suspension / E-axle	
Tyres	205/75 R 17.5	
Wheel	17.5 x 6.00 - 115	
Steering	Right-hand drive	Recirculating ball steering with power assist, tilting telescopic steering column with steering-wheel lock
Brake	Service brake	Hydraulic with vacuum power assist, dual-circuit with load-dependent brake proportioning valve at rear wheels
	Front / rear	Disc brake (293 x 40 mm / 314 x 35 mm)
	Parking brake	Electromechanical brake caliper on rear disc brake
Suspension	Front / rear	Coil springs with shock absorber / Semi-elliptic leaf springs with shock absorber and stabilizer
Frame	Type	Ladder-type frame with reinforcements and crossmembers
Electrical system	Low voltage batteries	Series 12 V (80 Ah) / optional 24 V (80 + 60 Ah)

3) The specified weight includes both the battery(ies) with 325 kg each and the peripheral installations (cabling, temperature control, protection, etc.).

4) The range depends on various factors such as load, driving style, topography, ambient temperature or weather, battery age, vehicle equipment. The actual range may vary.

The given values for the range were tested with a box body, a load of 50% of the payload, an ambient temperature of 20 °C and an average battery age.

5) The charging time depends on various factors such as the charging capacity of the vehicle and charging station, the battery's state of charge, ambient and battery temperature.

The given values for the charging time were tested under optimum ambient temperature of 20 °C.

The illustrations may contain accessories and items of optional equipment which are not part of the standard specification. The data sheet may contain product types and support services not available in certain countries.

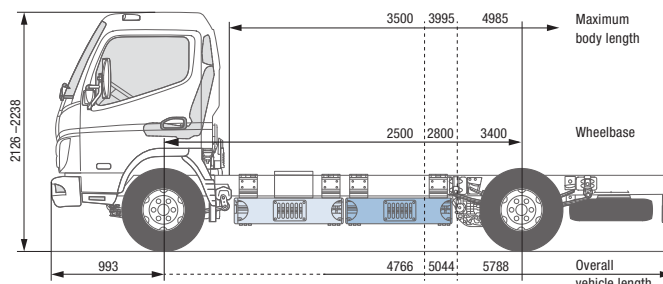
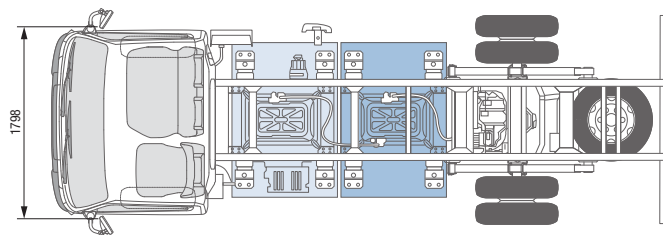

eCANTER 6S15e

LEFT-HAND DRIVE

MODEL / VEHICLE TYPE

	6S15e			
Cab type / crew	Standard, single cab / 3			
Battery variant	S			M
Model variant	84004212	84004312	84004512	84005512
FUSO model code	FEAVKBLCSEU1	FEAVKCLCSEU1	FEAVKELCSEU1	FEAVKELDSEU1

DIMENSIONS (MM)

Wheelbase	2500	2800	3400	
Overall length	4766	5044	5788	
Cab length	1510			
Width overall	1869			
Cab width	1798			
Height overall	2160–2237	2159–2238	2157–2246	2152–2222
Track width	Front / rear		1390 / 1435	
Frame height (at end of frame)	150			
Ground clearance	260			250
Cab to rear axle	1975	2279	2879	
Cab to end of frame	3128	3478	4278	
Maximum body length ²⁾	3500	3995	4985	
Frame width	701			
Front overhang	993			
Rear overhang	1145	1195	1395	
Front axle to front of body	625			
Recommended distance cab to body	100			

WEIGHTS (KG)

Empty weight ¹⁾		2515	2525	2550	3025
	Front / rear	1408 / 1107	1414 / 1111	1428 / 1122	1603 / 1422
Minimum vehicle weight		2705	2715	2740	3215
Gross vehicle weight		6000			
Axle loads ¹⁾	Front / rear	2600 / 4500			
Chassis load bearing capacity ²⁾		3485	3475	3450	2975

DRIVING PERFORMANCE AND AGILITY

Maximum speed	km/h	89			
Minimum turning circle (m)	Kerb to kerb	9.8	10.8	12.8	
	Wall to wall	10.8	12.0	14.0	

1) The weight refers to the base vehicle (European series, including high voltage battery, tyre sealant, tools and driver with 75 kg) without optional equipment. If any optional equipment is added, the weight changes accordingly.

2) Calculated maximum value which should be checked depending on the body and application. Subject to change without notice. All data is approximate.

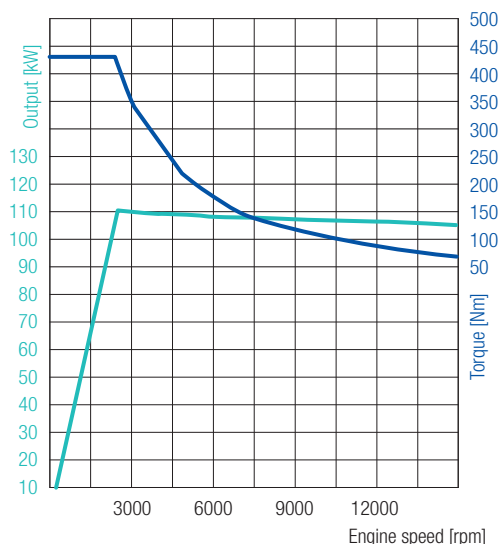

110 kW (150 hp)
430 Nm

eCANTER 6S15e

LEFT-HAND DRIVE

ELECTRIC DRIVE

Type	S40		
Peak output / continuous output	110 kW (150 hp) / 85 kW (116 hp)		
Maximum torque / continuous torque	430 Nm / 250 Nm		
PTO (optional)	Type	mPTO with pump connection	mPTO with pulley
	Maximum torque	222 Nm at 2000 rpm	64 Nm at 7000 rpm
	Continuous power / torque	17 kW / 166 Nm, maximum 2000 rpm	17 kW / 46 Nm, maximum 7000 rpm
	Gear ratio	0.286	–

HIGH VOLTAGE BATTERY

Battery variant	S		M
Capacity usable / installed	kWh	39 / 41	78 / 82
Weight ³⁾	kg	475	950
Range ⁴⁾	km	70	140

CHARGING

Connection type / variants	CCS TYP 2 (AC / DC)		
Maximum charging capacity AC / DC	kW	11 / 70	22 / 104
Maximum charging time AC ⁵⁾	0–100 % h:min	4:12	4:54
Maximum charging time DC ⁵⁾	20–80 % h:min	0:24	0:26
	5–90 % h:min	0:36	0:44

POWERTRAIN

Climbing ability	20 %
------------------	------

CHASSIS

Front axle / rear axle	Independent suspension / E-axle		
Tyres	205/75 R 17.5		
Wheel	17.5 x 6.00 - 115		
Steering	Left-hand drive	Recirculating ball steering with power assist, tilting telescopic steering column with steering-wheel lock	
Brake	Service brake	Hydraulic with vacuum power assist, dual-circuit with load-dependent brake proportioning valve at rear wheels	
	Front / rear	Disc brake (293 x 40 mm / 314 x 35 mm)	
	Parking brake	Electromechanical brake caliper on rear disc brake	
Suspension	Front / rear	Coil springs with shock absorber / Semi-elliptic leaf springs with shock absorber and stabilizer	
Frame	Type	Ladder-type frame with reinforcements and crossmembers	
Electrical system	Low voltage batteries	Series 12 V (80 Ah) / optional 24 V (80 + 60 Ah)	

3) The specified weight includes both the battery(ies) with 325 kg each and the peripheral installations (cabling, temperature control, protection, etc.).

4) The range depends on various factors such as load, driving style, topography, ambient temperature or weather, battery age, vehicle equipment. The actual range may vary.

The given values for the range were tested with a box body, a load of 50% of the payload, an ambient temperature of 20 °C and an average battery age.

5) The charging time depends on various factors such as the charging capacity of the vehicle and charging station, the battery's state of charge, ambient and battery temperature.

The given values for the charging time were tested under optimum ambient temperature of 20 °C.

The illustrations may contain accessories and items of optional equipment which are not part of the standard specification. The data sheet may contain product types and support services not available in certain countries.

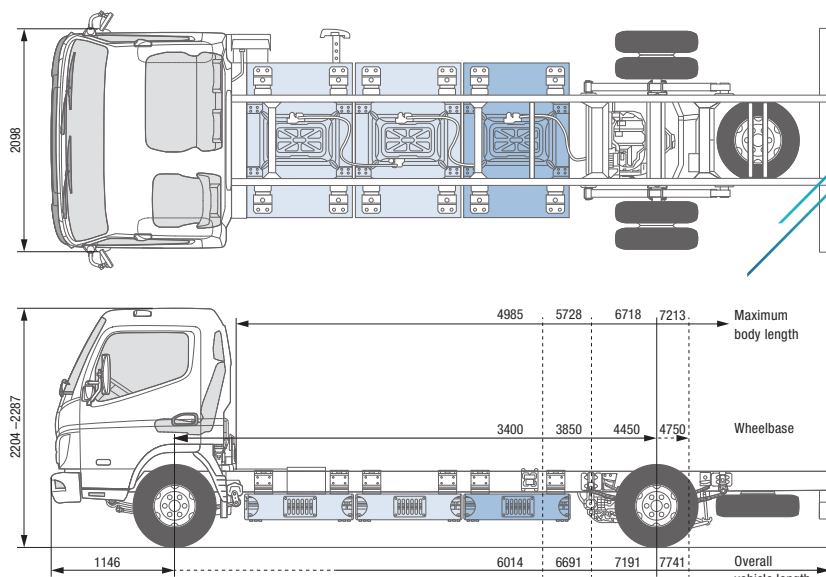

eCANTER 7C18e LEFT-HAND DRIVE

MODEL / VEHICLE TYPE

	7C18e			
Cab type / crew	Comfort, single cab / 3			
Battery variant	M			
Model variant	84006515	84006715	84006815	84006915
FUSO model code	FEC7KELDSEU2	FEC7KGLDSEU2	FEC7KHLDSEU2	FEC7KKLDSEU2

DIMENSIONS (MM)

Wheelbase		3400	3850	4450	4750
Overall length		6014	6691	7191	7741
Cab length				1631	
Width overall				2126	
Cab width				2098	
Height overall		2214–2287	2213–2286	2206–2261	2204–2281
Track width	Front / rear			1665 / 1660	
Frame height (at end of frame)				212	
Ground clearance		255	275		270
Cab to rear axle		2875	3325	3925	4229
Cab to end of frame		4310	5060	5560	6110
Maximum body length ²⁾		4985	5728	6718	7213
Frame width				850	
Front overhang				1146	
Rear overhang		1395	1695	1595	1845
Front axle to front of body				625	
Recommended distance cab to body				100	

WEIGHTS (KG)

Empty weight ¹⁾		3245	3270	3295	3320
	Front / rear	1720 / 1525	1733 / 1537	1746 / 1549	1760 / 1560
Minimum vehicle weight		3440	3465	3490	3515
Gross vehicle weight				7490	
Axle loads ¹⁾	Front / rear			3100 / 5990	
Chassis load bearing capacity ²⁾		4245	4220	4195	4170

DRIVING PERFORMANCE AND AGILITY

Maximum speed	km/h			89	
Minimum turning circle (m)	Kerb to kerb	12.4	13.8	15.6	16.6
	Wall to wall	13.8	15.8	17.2	18.0

¹⁾ The weight refers to the base vehicle (European series, including high voltage battery, tyre sealant, tools and driver with 75 kg) without optional equipment. If any optional equipment is added, the weight changes accordingly.

²⁾ Calculated maximum value which should be checked depending on the body and application. Subject to change without notice. All data is approximate.

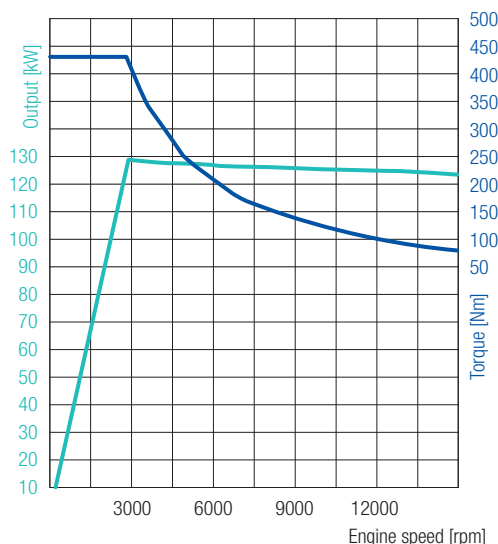

eCANTER 7C18e

LEFT-HAND DRIVE

129 kW (175 hp)
430 Nm

ELECTRIC DRIVE

Type	S40		
Peak output / continuous output	129 kW (175 hp) / 110 kW (150 hp)		
Maximum torque / continuous torque	430 Nm / 250 Nm		
PTO (optional)	Type	mPTO with pump connection	mPTO with pulley
	Maximum torque	222 Nm at 2000 rpm	64 Nm at 7000 rpm
	Continuous power / torque	17 kW / 166 Nm, maximum 2000 rpm	17 kW / 46 Nm, maximum 7000 rpm
	Gear ratio	0.286	–

HIGH VOLTAGE BATTERY

Battery variant	M		
Capacity usable / installed	kWh	78 / 82	
Weight ³⁾	kg	900	
Range ⁴⁾	km	140	

CHARGING

Connection type / variants	CCS TYP 2 (AC / DC)		
Maximum charging capacity AC / DC	kW	22 / 104	
Maximum charging time AC ⁵⁾	0–100 %	h:min	4:54
Maximum charging time DC ⁵⁾	20–80 %	h:min	0:26
	5–90 %	h:min	0:44

POWERTRAIN

Climbing ability	20 %		
------------------	------	--	--

CHASSIS

Front axle / rear axle	Leaf springs / E-axle		
Tyres	205/75 R 17.5		
Wheel	17.5 x 6.00 - 127		
Steering	Left-hand drive	Recirculating ball steering with power assist, tilting telescopic steering column with steering-wheel lock	
Brake	Service brake	Hydraulic with vacuum power assist, dual-circuit with load-dependent brake proportioning valve at rear wheels	
	Front / rear	Disc brake (310 x 40 mm / 314 x 35 mm)	
	Parking brake	Electromechanical brake caliper on rear disc brake	
Suspension	Front / rear	Semi-elliptic leaf springs with shock absorber and stabilizer	
Frame	Type	Ladder-type frame with reinforcements and crossmembers	
Electrical system	Low voltage batteries	Series 12 V (80 Ah) / optional 24 V (80 + 60 Ah)	

3) The specified weight includes both the battery(ies) with 325 kg each and the peripheral installations (cabling, temperature control, protection, etc.).

4) The range depends on various factors such as load, driving style, topography, ambient temperature or weather, battery age, vehicle equipment. The actual range may vary.

The given values for the range were tested with a box body, a load of 50% of the payload, an ambient temperature of 20 °C and an average battery age.

5) The charging time depends on various factors such as the charging capacity of the vehicle and charging station, the battery's state of charge, ambient and battery temperature.

The given values for the charging time were tested under optimum ambient temperature of 20 °C.

The illustrations may contain accessories and items of optional equipment which are not part of the standard specification. The data sheet may contain product types and support services not available in certain countries.

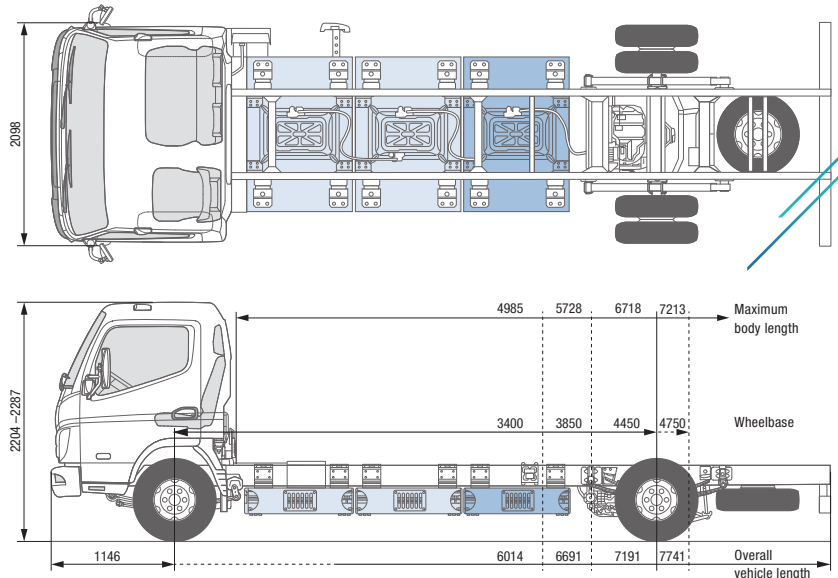

eCANTER 7C18e

LEFT-HAND DRIVE

MODEL / VEHICLE TYPE		7C18e	
Cab type / crew		Comfort, single cab / 3	
Battery variant		L	
Model variant		84007815	84007915
FUSO model code		FEC7KHLESEU2	FEC7KKLESEU2
DIMENSIONS (MM)			
Wheelbase		4450	4750
Overall length		7191	7741
Cab length			1631
Width overall			2126
Cab width			2098
Height overall		2206–2261	2209–2281
Track width	Front / rear		1665 / 1660
Frame height (at end of frame)			212
Ground clearance			270
Cab to rear axle		3925	4229
Cab to end of frame		5560	6110
Maximum body length ²⁾		6718	7213
Frame width			850
Front overhang			1146
Rear overhang		1595	1845
Front axle to front of body			625
Recommended distance cab to body			100
WEIGHTS (KG)			
Empty weight ¹⁾		3745	3870
	Front / rear	1985 / 1760	1998 / 1772
Minimum vehicle weight		3940	3965
Gross vehicle weight			7490
Axle loads ¹⁾	Front / rear		3100 / 5990
Chassis load bearing capacity ²⁾		3745	3720
DRIVING PERFORMANCE AND AGILITY			
Maximum speed	km/h		89
Minimum turning circle (m)	Kerb to kerb	15.6	16.6
	Wall to wall	17.2	18.0

1) The weight refers to the base vehicle (European series, including high voltage battery, tyre sealant, tools and driver with 75 kg) without optional equipment. If any optional equipment is added, the weight changes accordingly.

2) Calculated maximum value which should be checked depending on the body and application. Subject to change without notice. All data is approximate.

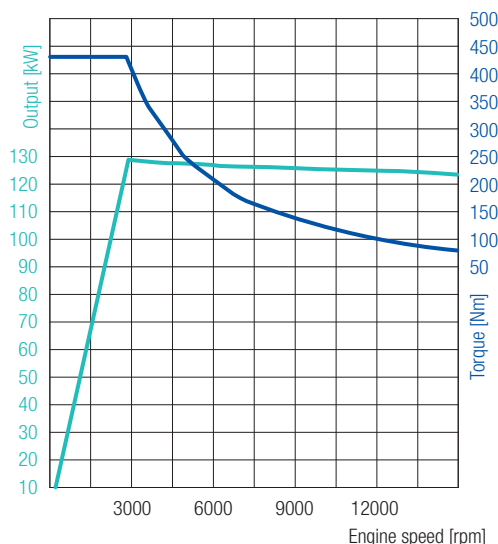

eCANTER 7C18e

LEFT-HAND DRIVE

129 kW (175 hp)
430 Nm

ELECTRIC DRIVE

Type	S40		
Peak output / continuous output	129 kW (175 hp) / 110 kW (150 hp)		
Maximum torque / continuous torque	430 Nm / 250 Nm		
PTO (optional)	Type	mPTO with pump connection	mPTO with pulley
	Maximum torque	222 Nm at 2000 rpm	64 Nm at 7000 rpm
	Continuous power / torque	17 kW / 166 Nm, maximum 2000 rpm	17 kW / 46 Nm, maximum 7000 rpm
	Gear ratio	0.286	–

HIGH VOLTAGE BATTERY

Battery variant	L		
Capacity usable / installed	kWh	116 / 124	
Weight ³⁾	kg	1350	
Range ⁴⁾	km	200	

CHARGING

Connection type / variants	CCS TYP 2 (AC / DC)		
Maximum charging capacity AC / DC	kW	22 / 104	
Maximum charging time AC ⁵⁾	0–100 %	h:min	6:00
Maximum charging time DC ⁵⁾	20–80 %	h:min	0:39
	5–90 %	h:min	1:16

POWERTRAIN

Climbing ability	20 %		
------------------	------	--	--

CHASSIS

Front axle / rear axle	Leaf springs / E-axle		
Tyres	205/75 R 17.5		
Wheel	17.5 x 6.00 - 127		
Steering	Left-hand drive	Recirculating ball steering with power assist, tilting telescopic steering column with steering-wheel lock	
Brake	Service brake	Hydraulic with vacuum power assist, dual-circuit with load-dependent brake proportioning valve at rear wheels	
	Front / rear	Disc brake (310 x 40 mm / 314 x 35 mm)	
	Parking brake	Electromechanical brake caliper on rear disc brake	
Suspension	Front / rear	Semi-elliptic leaf springs with shock absorber and stabilizer	
Frame	Type	Ladder-type frame with reinforcements and crossmembers	
Electrical system	Low voltage batteries	Series 12 V (80 Ah) / optional 24 V (80 + 60 Ah)	

3) The specified weight includes both the battery(ies) with 325 kg each and the peripheral installations (cabling, temperature control, protection, etc.).

4) The range depends on various factors such as load, driving style, topography, ambient temperature or weather, battery age, vehicle equipment. The actual range may vary.

The given values for the range were tested with a box body, a load of 50% of the payload, an ambient temperature of 20 °C and an average battery age.

5) The charging time depends on various factors such as the charging capacity of the vehicle and charging station, the battery's state of charge, ambient and battery temperature.

The given values for the charging time were tested under optimum ambient temperature of 20 °C.

The illustrations may contain accessories and items of optional equipment which are not part of the standard specification. The data sheet may contain product types and support services not available in certain countries.

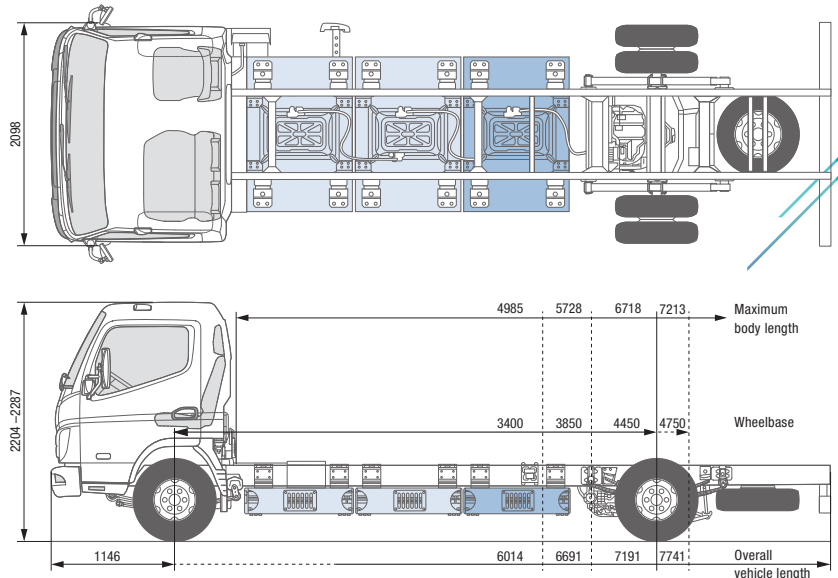

eCANTER 7C18e RIGHT-HAND DRIVE

MODEL / VEHICLE TYPE

	7C18e			
Cab type / crew	Comfort, single cab / 3			
Battery variant	M			
Model variant	84006525	84006725	84006825	84006925
FUSO model code	FEC7KERDSEU2	FEC7KGRDSEU2	FEC7KHRDSEU2	FEC7KKRDSEU2

DIMENSIONS (MM)

Wheelbase		3400	3850	4450	4750
Overall length		6014	6691	7191	7741
Cab length				1631	
Width overall				2126	
Cab width				2098	
Height overall		2214–2287	2213–2286	2206–2261	2204–2281
Track width	Front / rear			1665 / 1660	
Frame height (at end of frame)				212	
Ground clearance		255	275		270
Cab to rear axle		2875	3325	3925	4229
Cab to end of frame		4310	5060	5560	6110
Maximum body length ²⁾		4985	5728	6718	7213
Frame width				850	
Front overhang				1146	
Rear overhang		1395	1695	1595	1845
Front axle to front of body				625	
Recommended distance cab to body				100	

WEIGHTS (KG)

Empty weight ¹⁾		3245	3270	3295	3320
	Front / rear	1720 / 1525	1733 / 1537	1746 / 1549	1760 / 1560
Minimum vehicle weight		3440	3465	3490	3515
Gross vehicle weight				7490	
Axle loads ¹⁾	Front / rear			3100 / 5990	
Chassis load bearing capacity ²⁾		4245	4220	4195	4170

DRIVING PERFORMANCE AND AGILITY

Maximum speed	km/h			89	
Minimum turning circle (m)	Kerb to kerb	12.4	13.8	15.6	16.6
	Wall to wall	13.8	15.8	17.2	18.0

¹⁾ The weight refers to the base vehicle (European series, including high voltage battery, tyre sealant, tools and driver with 75 kg) without optional equipment. If any optional equipment is added, the weight changes accordingly.

²⁾ Calculated maximum value which should be checked depending on the body and application. Subject to change without notice. All data is approximate.

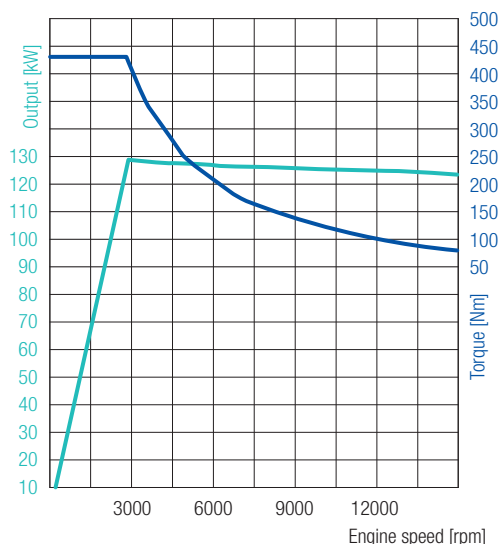

eCANTER 7C18e RIGHT-HAND DRIVE

129 kW (175 hp)
430 Nm

ELECTRIC DRIVE

Type	S40		
Peak output / continuous output	129 kW (175 hp) / 110 kW (150 hp)		
Maximum torque / continous torque	430 Nm / 250 Nm		
PTO (optional)	Type	mPTO with pump connection	mPTO with pulley
	Maximum torque	222 Nm at 2000 rpm	64 Nm at 7000 rpm
	Continuous power / torque	17 kW / 166 Nm, maximum 2000 rpm	17 kW / 46 Nm, maximum 7000 rpm
	Gear ratio	0.286	–

HIGH VOLTAGE BATTERY

Battery variant	M		
Capacity usable / installed	kWh	78 / 82	
Weight ³⁾	kg	900	
Range ⁴⁾	km	140	

CHARGING

Connection type / variants	CCS TYP 2 (AC / DC)		
Maximum charging capacity AC / DC	kW	22 / 104	
Maximum charging time AC ⁵⁾	0–100 %	h:min	4:54
Maximum charging time DC ⁵⁾	20–80 %	h:min	0:26
	5–90 %	h:min	0:44

POWERTRAIN

Climbing ability	20 %		
------------------	------	--	--

CHASSIS

Front axle / rear axle	Leaf springs / E-axle		
Tyres	205/75 R 17.5		
Wheel	17.5 x 6.00 - 127		
Steering	Right-hand drive	Recirculating ball steering with power assist, tilting telescopic steering column with steering-wheel lock	
Brake	Service brake	Hydraulic with vacuum power assist, dual-circuit with load-dependent brake proportioning valve at rear wheels	
	Front / rear	Disc brake (310 x 40 mm / 314 x 35 mm)	
	Parking brake	Electromechanical brake caliper on rear disc brake	
Suspension	Front / rear	Semi-elliptic leaf springs with shock absorber and stabilizer	
Frame	Type	Ladder-type frame with reinforcements and crossmembers	
Electrical system	Low voltage batteries	Series 12 V (80 Ah) / optional 24 V (80 + 60 Ah)	

3) The specified weight includes both the battery(ies) with 325 kg each and the peripheral installations (cabling, temperature control, protection, etc.).

4) The range depends on various factors such as load, driving style, topography, ambient temperature or weather, battery age, vehicle equipment. The actual range may vary.

The given values for the range were tested with a box body, a load of 50% of the payload, an ambient temperature of 20 °C and an average battery age.

5) The charging time depends on various factors such as the charging capacity of the vehicle and charging station, the battery's state of charge, ambient and battery temperature.

The given values for the charging time were tested under optimum ambient temperature of 20 °C.

The illustrations may contain accessories and items of optional equipment which are not part of the standard specification. The data sheet may contain product types and support services not available in certain countries.

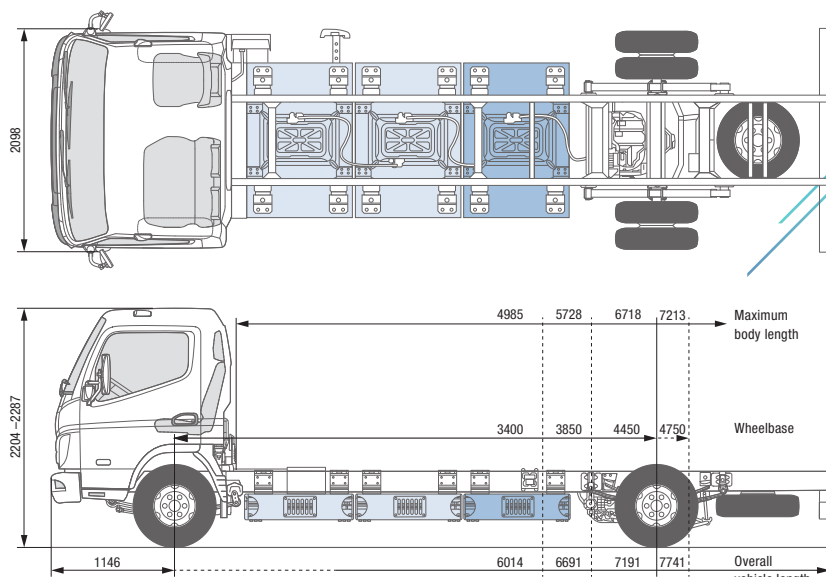

eCANTER 7C18e RIGHT-HAND DRIVE

MODEL / VEHICLE TYPE		7C18e	
Cab type / crew		Comfort, single cab / 3	
Battery variant		L	
Model variant		84007825	84007925
FUSO model code		FEC7KHRESEU2	FEC7KKRESEU2
DIMENSIONS (MM)			
Wheelbase		4450	4750
Overall length		7191	7741
Cab length			1631
Width overall			2126
Cab width			2098
Height overall		2206–2261	2209–2281
Track width	Front / rear		1665 / 1660
Frame height (at end of frame)			212
Ground clearance			270
Cab to rear axle		3925	4229
Cab to end of frame		5560	6110
Maximum body length ²⁾		6718	7213
Frame width			850
Front overhang			1146
Rear overhang		1595	1845
Front axle to front of body			625
Recommended distance cab to body			100
WEIGHTS (KG)			
Empty weight ¹⁾		3745	3870
	Front / rear	1985 / 1760	1998 / 1772
Minimum vehicle weight		3940	3965
Gross vehicle weight			7490
Axle loads ¹⁾	Front / rear		3100 / 5990
Chassis load bearing capacity ²⁾		3745	3720
DRIVING PERFORMANCE AND AGILITY			
Maximum speed	km/h		89
Minimum turning circle (m)	Kerb to kerb	15.6	16.6
	Wall to wall	17.2	18.0

¹⁾ The weight refers to the base vehicle (European series, including high voltage battery, tyre sealant, tools and driver with 75 kg) without optional equipment. If any optional equipment is added, the weight changes accordingly.

²⁾ Calculated maximum value which should be checked depending on the body and application. Subject to change without notice. All data is approximate.

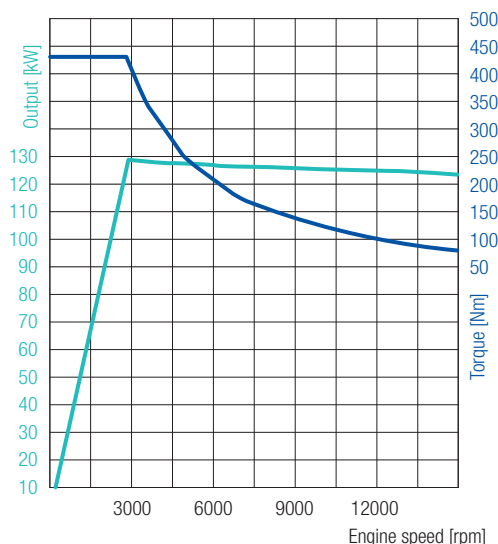

eCANTER 7C18e RIGHT-HAND DRIVE

129 kW (175 hp)
430 Nm

ELECTRIC DRIVE

Type	S40		
Peak output / continuous output	129 kW (175 hp) / 110 kW (150 hp)		
Maximum torque / continuous torque	430 Nm / 250 Nm		
PTO (optional)	Type	mPTO with pump connection	mPTO with pulley
	Maximum torque	222 Nm at 2000 rpm	64 Nm at 7000 rpm
	Continuous power / torque	17 kW / 166 Nm, maximum 2000 rpm	17 kW / 46 Nm, maximum 7000 rpm
	Gear ratio	0.286	–

HIGH VOLTAGE BATTERY

Battery variant	L		
Capacity usable / installed	kWh	116 / 124	
Weight ³⁾	kg	1350	
Range ⁴⁾	km	200	

CHARGING

Connection type / variants	CCS TYP 2 (AC / DC)		
Maximum charging capacity AC / DC	kW	22 / 104	
Maximum charging time AC ⁵⁾	0–100 %	h:min	6:00
Maximum charging time DC ⁵⁾	20–80 %	h:min	0:39
	5–90 %	h:min	1:16

POWERTRAIN

Climbing ability	20 %
------------------	------

CHASSIS

Front axle / rear axle	Leaf springs / E-axle		
Tyres	205/75 R 17.5		
Wheel	17.5 x 6.00 - 127		
Steering	Right-hand drive	Recirculating ball steering with power assist, tilting telescopic steering column with steering-wheel lock	
Brake	Service brake	Hydraulic with vacuum power assist, dual-circuit with load-dependent brake proportioning valve at rear wheels	
	Front / rear	Disc brake (310 x 40 mm / 314 x 35 mm)	
	Parking brake	Electromechanical brake caliper on rear disc brake	
Suspension	Front / rear	Semi-elliptic leaf springs with shock absorber and stabilizer	
Frame	Type	Ladder-type frame with reinforcements and crossmembers	
Electrical system	Low voltage batteries	Series 12 V (80 Ah) / optional 24 V (80 + 60 Ah)	

3) The specified weight includes both the battery(ies) with 325 kg each and the peripheral installations (cabling, temperature control, protection, etc.).

4) The range depends on various factors such as load, driving style, topography, ambient temperature or weather, battery age, vehicle equipment. The actual range may vary.

The given values for the range were tested with a box body, a load of 50% of the payload, an ambient temperature of 20 °C and an average battery age.

5) The charging time depends on various factors such as the charging capacity of the vehicle and charging station, the battery's state of charge, ambient and battery temperature.

The given values for the charging time were tested under optimum ambient temperature of 20 °C.

The illustrations may contain accessories and items of optional equipment which are not part of the standard specification. The data sheet may contain product types and support services not available in certain countries.

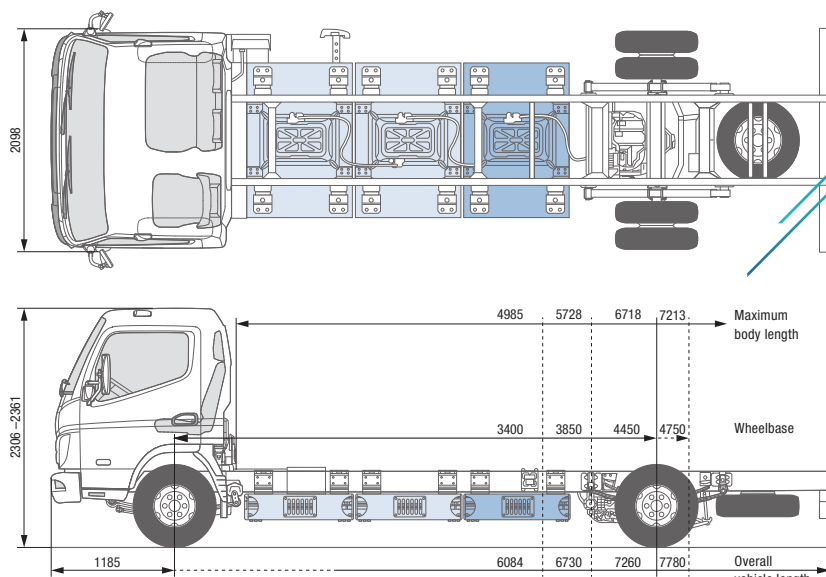

eCANTER 9C18e

LEFT-HAND DRIVE

MODEL / VEHICLE TYPE

	9C18e			
Cab type / crew	Comfort, single cab / 3			
Battery variant	M			
Model variant	84008515	84008715	84008815	84008915
FUSO model code	FECXKELDSEU2	FECXKGLDSEU2	FECXKHLDSEU2	FECXKKLDSEU2

DIMENSIONS (MM)

Wheelbase		3400	3850	4450	4750
Overall length		6084	6730	7260	7780
Cab length				1631	
Width overall				2153	
Cab width				2098	
Height overall			2315–2368		2306–2361
Track width	Front / rear			1665 / 1660	
Frame height (at end of frame)				212	
Ground clearance			310		305
Cab to rear axle		2875	3325	3925	4225
Cab to end of frame		4349	5099	5599	6149
Maximum body length ²⁾		4985	5728	6718	7213
Frame width				850	
Front overhang				1185	
Rear overhang		1395	1695	1595	1845
Front axle to front of body				625	
Recommended distance cab to body				100	

WEIGHTS (KG)

Empty weight ¹⁾		3415	3440	3465	3490
	Front / rear	1810 / 1605	1806 / 1634	1802 / 1663	1850 / 1640
Minimum vehicle weight		3620	3645	3670	3695
Gross vehicle weight				8550	
Axle loads ¹⁾	Front / rear			3400 / 5990	
Chassis load bearing capacity ²⁾		5135	5110	5085	5060

DRIVING PERFORMANCE AND AGILITY

Maximum speed	km/h			89	
Minimum turning circle (m)	Kerb to kerb	13.0	14.6	16.6	17.6
	Wall to wall	14.4	16.0	18.0	19.0

1) The weight refers to the base vehicle (European series, including high voltage battery, tyre sealant, tools and driver with 75 kg) without optional equipment. If any optional equipment is added, the weight changes accordingly.
 2) Calculated maximum value which should be checked depending on the body and application.
 Subject to change without notice. All data is approximate.

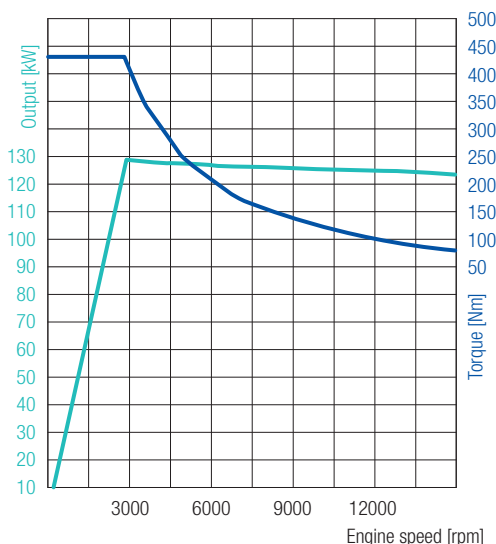

eCANTER 9C18e LEFT-HAND DRIVE

129 kW (175 hp)
430 Nm

ELECTRIC DRIVE

Type	S40		
Peak output / continuous output	129 kW (175 hp) / 110 kW (150 hp)		
Maximum torque / continous torque	430 Nm / 250 Nm		
PTO (optional)	Type	mPTO with pump connection	mPTO with pulley
	Maximum torque	222 Nm at 2000 rpm	64 Nm at 7000 rpm
	Continuous power / torque	17 kW / 166 Nm, maximum 2000 rpm	17 kW / 46 Nm, maximum 7000 rpm
	Gear ratio	0.286	–

HIGH VOLTAGE BATTERY

Battery variant	M		
Capacity usable / installed	kWh	78 / 82	
Weight ³⁾	kg	930	
Range ⁴⁾	km	140	

CHARGING

Connection type / variants	CCS TYP 2 (AC / DC)		
Maximum charging capacity AC / DC	kW	22 / 104	
Maximum charging time AC ⁵⁾	0–100 %	h:min	4:54
Maximum charging time DC ⁵⁾	20–80 %	h:min	0:26
	5–90 %	h:min	0:44

POWERTRAIN

Climbing ability	20 %		
------------------	------	--	--

CHASSIS

Front axle / rear axle	Leaf springs / E-axle		
Tyres	225/70 R 19.5		
Wheel	19.5 x 6.00 - 127		
Steering	Left-hand drive	Recirculating ball steering with power assist, tilting telescopic steering column with steering-wheel lock	
Brake	Service brake	Hydraulic with vacuum power assist, dual-circuit with load-dependent brake proportioning valve at rear wheels	
	Front / rear	Disc brake (355 x 42 mm)	
	Parking brake	Electromechanical brake caliper on rear disc brake	
Suspension	Front / rear	Semi-elliptic leaf springs with shock absorber and stabilizer	
Frame	Type	Ladder-type frame with reinforcements and crossmembers	
Electrical system	Low voltage batteries	Series 12 V (80 Ah) / optional 24 V (80 + 60 Ah)	

3) The specified weight includes both the battery(ies) with 325 kg each and the peripheral installations (cabling, temperature control, protection, etc.).

4) The range depends on various factors such as load, driving style, topography, ambient temperature or weather, battery age, vehicle equipment. The actual range may vary.

The given values for the range were tested with a box body, a load of 50% of the payload, an ambient temperature of 20 °C and an average battery age.

5) The charging time depends on various factors such as the charging capacity of the vehicle and charging station, the battery's state of charge, ambient and battery temperature.

The given values for the charging time were tested under optimum ambient temperature of 20 °C.

The illustrations may contain accessories and items of optional equipment which are not part of the standard specification. The data sheet may contain product types and support services not available in certain countries.

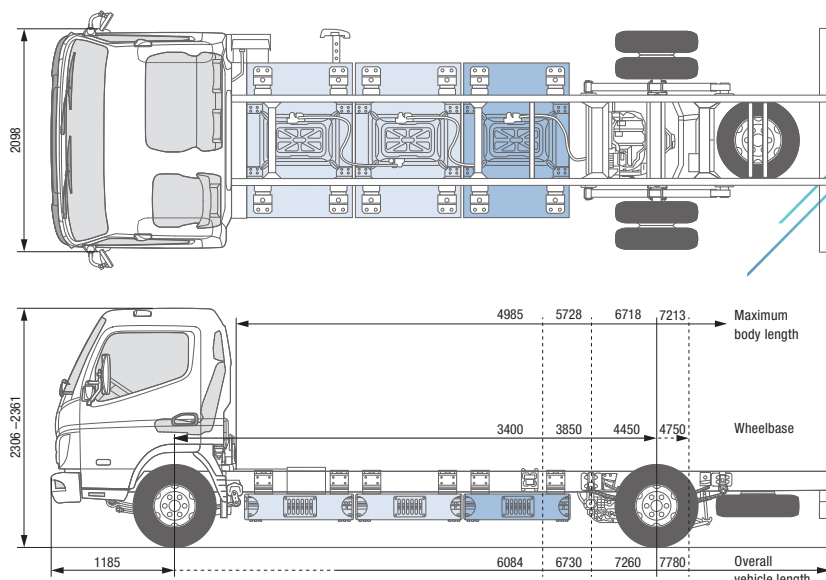

eCANTER 9C18e

LEFT-HAND DRIVE

MODEL / VEHICLE TYPE		9C18e	
Cab type / crew		Comfort, single cab / 3	
Battery variant		L	
Model variant		84009815	84009915
FUSO model code		FECXKHLESEU2	FECXKKLESEU2
DIMENSIONS (MM)			
Wheelbase		4450	4750
Overall length		7230	7780
Cab length			1631
Width overall			2153
Cab width			2098
Height overall			2306–2361
Track width	Front / rear		1665 / 1660
Frame height (at end of frame)			212
Ground clearance			305
Cab to rear axle		3925	4225
Cab to end of frame		5599	6149
Maximum body length ²⁾		6718	7213
Frame width			850
Front overhang			1185
Rear overhang		1595	1845
Front axle to front of body			625
Recommended distance cab to body			100
WEIGHTS (KG)			
Empty weight ¹⁾		3930	3955
	Front / rear	2004 / 1926	2017 / 1938
Minimum vehicle weight		4135	4160
Gross vehicle weight			8550
Axle loads ¹⁾	Front / rear		3400 / 5990
Chassis load bearing capacity ²⁾		4620	4595
DRIVING PERFORMANCE AND AGILITY			
Maximum speed	km/h		89
Minimum turning circle (m)	Kerb to kerb	16.6	17.6
	Wall to wall	18.0	19.0

1) The weight refers to the base vehicle (European series, including high voltage battery, tyre sealant, tools and driver with 75 kg) without optional equipment. If any optional equipment is added, the weight changes accordingly.

2) Calculated maximum value which should be checked depending on the body and application. Subject to change without notice. All data is approximate.

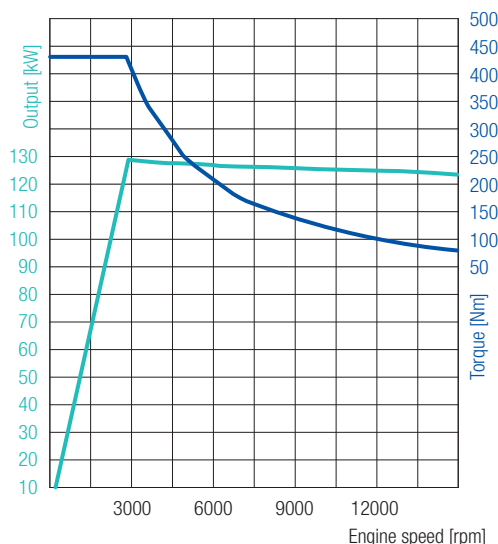

eCANTER 9C18e

LEFT-HAND DRIVE

129 kW (175 hp)
430 Nm

ELECTRIC DRIVE

Type	S40		
Peak output / continuous output	129 kW (175 hp) / 110 kW (150 hp)		
Maximum torque / continuous torque	430 Nm / 250 Nm		
PTO (optional)	Type	mPTO with pump connection	mPTO with pulley
	Maximum torque	222 Nm at 2000 rpm	64 Nm at 7000 rpm
	Continuous power / torque	17 kW / 166 Nm, maximum 2000 rpm	17 kW / 46 Nm, maximum 7000 rpm
	Gear ratio	0.286	–

HIGH VOLTAGE BATTERY

Battery variant	L		
Capacity usable / installed	kWh	116 / 124	
Weight ³⁾	kg	1395	
Range ⁴⁾	km	200	

CHARGING

Connection type / variants	CCS TYP 2 (AC / DC)		
Maximum charging capacity AC / DC	kW	22 / 104	
Maximum charging time AC ⁵⁾	0–100 %	h:min	6:00
Maximum charging time DC ⁵⁾	20–80 %	h:min	0:39
	5–90 %	h:min	1:16

POWERTRAIN

Climbing ability	20 %		
------------------	------	--	--

CHASSIS

Front axle / rear axle	Leaf springs / E-axle		
Tyres	225/70 R 19.5		
Wheel	19.5 x 6.00 - 127		
Steering	Left-hand drive	Recirculating ball steering with power assist, tilting telescopic steering column with steering-wheel lock	
Brake	Service brake	Hydraulic with vacuum power assist, dual-circuit with load-dependent brake proportioning valve at rear wheels	
	Front / rear	Disc brake (355 x 42 mm)	
	Parking brake	Electromechanical brake caliper on rear disc brake	
Suspension	Front / rear	Semi-elliptic leaf springs with shock absorber and stabilizer	
Frame	Type	Ladder-type frame with reinforcements and crossmembers	
Electrical system	Low voltage batteries	Series 12 V (80 Ah) / optional 24 V (80 + 60 Ah)	

3) The specified weight includes both the battery(ies) with 325 kg each and the peripheral installations (cabling, temperature control, protection, etc.).

4) The range depends on various factors such as load, driving style, topography, ambient temperature or weather, battery age, vehicle equipment. The actual range may vary.

The given values for the range were tested with a box body, a load of 50% of the payload, an ambient temperature of 20 °C and an average battery age.

5) The charging time depends on various factors such as the charging capacity of the vehicle and charging station, the battery's state of charge, ambient and battery temperature.

The given values for the charging time were tested under optimum ambient temperature of 20 °C.

The illustrations may contain accessories and items of optional equipment which are not part of the standard specification. The data sheet may contain product types and support services not available in certain countries.

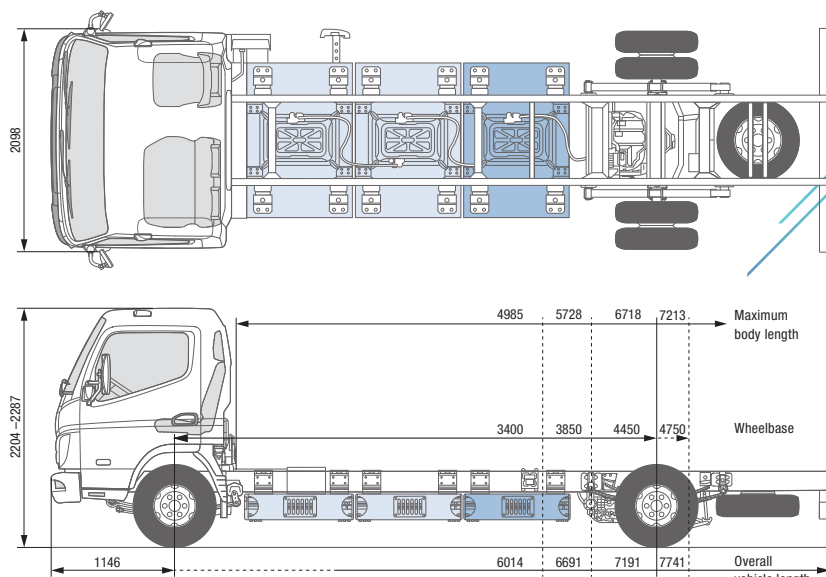

eCANTER 9C18e RIGHT-HAND DRIVE

MODEL / VEHICLE TYPE

	9C18e			
Cab type / crew	Comfort, single cab / 3			
Battery variant	M			
Model variant	84008525	84008725	84008825	84008925
FUSO model code	FECXKERDSEU2	FECXKGRDSEU2	FECXKHRDSEU2	FECXKKRDSEU2

DIMENSIONS (MM)

Wheelbase		3400	3850	4450	4750
Overall length		6084	6730	7260	7780
Cab length				1631	
Width overall				2153	
Cab width				2098	
Height overall			2315–2368		2306–2361
Track width	Front / rear			1665 / 1660	
Frame height (at end of frame)				212	
Ground clearance			310		305
Cab to rear axle		2875	3325	3925	4225
Cab to end of frame		4349	5099	5599	6149
Maximum body length ²⁾		4985	5728	6718	7213
Frame width				850	
Front overhang				1185	
Rear overhang		1395	1695	1595	1845
Front axle to front of body				625	
Recommended distance cab to body				100	

WEIGHTS (KG)

Empty weight ¹⁾		3415	3440	3465	3490
	Front / rear	1810 / 1605	1806 / 1634	1802 / 1663	1850 / 1640
Minimum vehicle weight		3620	3645	3670	3695
Gross vehicle weight				8550	
Axle loads ¹⁾	Front / rear			3400 / 5990	
Chassis load bearing capacity ²⁾		5135	5110	5085	5060

DRIVING PERFORMANCE AND AGILITY

Maximum speed	km/h			89	
Minimum turning circle (m)	Kerb to kerb	13.0	14.6	16.6	17.6
	Wall to wall	14.4	16.0	18.0	19.0

1) The weight refers to the base vehicle (European series, including high voltage battery, tyre sealant, tools and driver with 75 kg) without optional equipment. If any optional equipment is added, the weight changes accordingly.

2) Calculated maximum value which should be checked depending on the body and application. Subject to change without notice. All data is approximate.

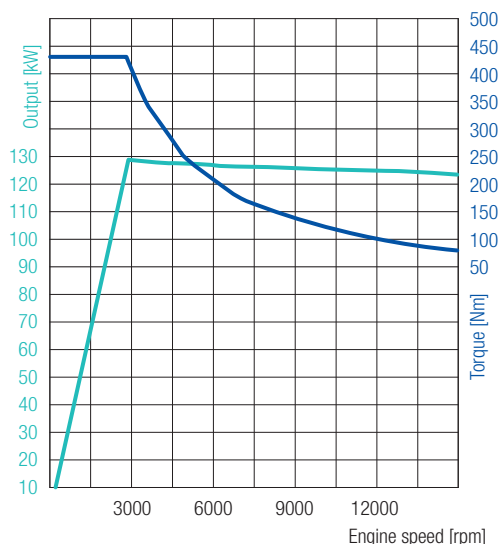

eCANTER 9C18e RIGHT-HAND DRIVE

129 kW (175 hp)
430 Nm

ELECTRIC DRIVE

Type	S40		
Peak output / continuous output	129 kW (175 hp) / 110 kW (150 hp)		
Maximum torque / continous torque	430 Nm / 250 Nm		
PTO (optional)	Type	mPTO with pump connection	mPTO with pulley
	Maximum torque	222 Nm at 2000 rpm	64 Nm at 7000 rpm
	Continuous power / torque	17 kW / 166 Nm, maximum 2000 rpm	17 kW / 46 Nm, maximum 7000 rpm
	Gear ratio	0.286	–

HIGH VOLTAGE BATTERY

Battery variant	M	
Capacity usable / installed	kWh	78 / 82
Weight ³⁾	kg	930
Range ⁴⁾	km	140

CHARGING

Connection type / variants	CCS TYP 2 (AC / DC)	
Maximum charging capacity AC / DC	kW	22 / 104
Maximum charging time AC ⁵⁾	0–100 % h:min	4:54
Maximum charging time DC ⁵⁾	20–80 % h:min	0:26
	5–90 % h:min	0:44

POWERTRAIN

Climbing ability	20 %
------------------	------

CHASSIS

Front axle / rear axle	Leaf springs / E-axle	
Tyres	225/70 R 19.5	
Wheel	19.5 x 6.00 - 127	
Steering	Right-hand drive	Recirculating ball steering with power assist, tilting telescopic steering column with steering-wheel lock
Brake	Service brake	Hydraulic with vacuum power assist, dual-circuit with load-dependent brake proportioning valve at rear wheels
	Front / rear	Disc brake (355 x 42 mm)
	Parking brake	Electromechanical brake caliper on rear disc brake
Suspension	Front / rear	Semi-elliptic leaf springs with shock absorber and stabilizer
Frame	Type	Ladder-type frame with reinforcements and crossmembers
Electrical system	Low voltage batteries	Series 12 V (80 Ah) / optional 24 V (80 + 60 Ah)

3) The specified weight includes both the battery(ies) with 325 kg each and the peripheral installations (cabling, temperature control, protection, etc.).

4) The range depends on various factors such as load, driving style, topography, ambient temperature or weather, battery age, vehicle equipment. The actual range may vary.

The given values for the range were tested with a box body, a load of 50% of the payload, an ambient temperature of 20 °C and an average battery age.

5) The charging time depends on various factors such as the charging capacity of the vehicle and charging station, the battery's state of charge, ambient and battery temperature.

The given values for the charging time were tested under optimum ambient temperature of 20 °C.

The illustrations may contain accessories and items of optional equipment which are not part of the standard specification. The data sheet may contain product types and support services not available in certain countries.

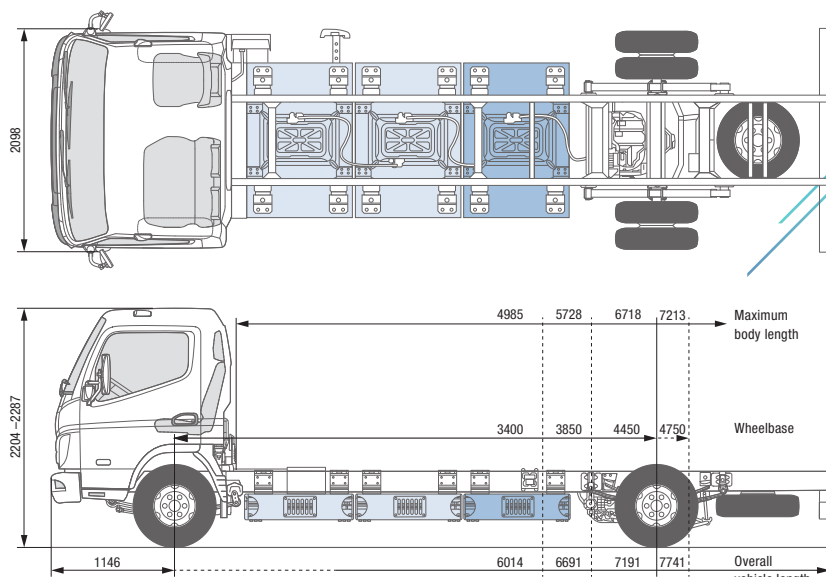

eCANTER 9C18e RIGHT-HAND DRIVE

MODEL / VEHICLE TYPE		9C18e	
Cab type / crew		Comfort, single cab / 3	
Battery variant		L	
Model variant		84009825	84009925
FUSO model code		FECXKHRESEU2	FECXKKRESEU2
DIMENSIONS (MM)			
Wheelbase		4450	4750
Overall length		7230	7780
Cab length		1631	
Width overall		2153	
Cab width		2098	
Height overall		2306–2361	
Track width	Front / rear	1665 / 1660	
Frame height (at end of frame)		212	
Ground clearance		305	
Cab to rear axle		3925	4225
Cab to end of frame		5599	6149
Maximum body length ²⁾		6718	7213
Frame width		850	
Front overhang		1185	
Rear overhang		1595	1845
Front axle to front of body		625	
Recommended distance cab to body		100	
WEIGHTS (KG)			
Empty weight ¹⁾		3930	3955
	Front / rear	2004 / 1926	2017 / 1938
Minimum vehicle weight		4135	4160
Gross vehicle weight		8550	
Axle loads ¹⁾	Front / rear	3400 / 5990	
Chassis load bearing capacity ²⁾		4620	4595
DRIVING PERFORMANCE AND AGILITY			
Maximum speed	km/h	89	
Minimum turning circle (m)	Kerb to kerb	16.6	17.6
	Wall to wall	18.0	19.0

¹⁾ The weight refers to the base vehicle (European series, including high voltage battery, tyre sealant, tools and driver with 75 kg) without optional equipment. If any optional equipment is added, the weight changes accordingly.

²⁾ Calculated maximum value which should be checked depending on the body and application. Subject to change without notice. All data is approximate.

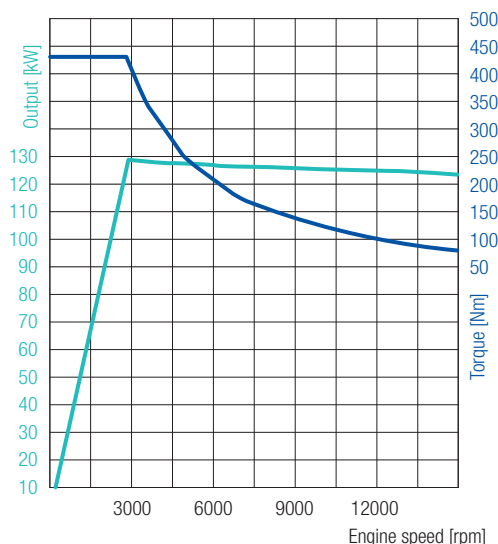

eCANTER 9C18e RIGHT-HAND DRIVE

129 kW (175 hp)
430 Nm

ELECTRIC DRIVE

Type	S40		
Peak output / continuous output	129 kW (175 hp) / 110 kW (150 hp)		
Maximum torque / continous torque	430 Nm / 250 Nm		
PTO (optional)	Type	mPTO with pump connection	mPTO with pulley
	Maximum torque	222 Nm at 2000 rpm	64 Nm at 7000 rpm
	Continuous power / torque	17 kW / 166 Nm, maximum 2000 rpm	17 kW / 46 Nm, maximum 7000 rpm
	Gear ratio	0.286	–

HIGH VOLTAGE BATTERY

Battery variant	L		
Capacity usable / installed	kWh	116 / 124	
Weight ³⁾	kg	1395	
Range ⁴⁾	km	200	

CHARGING

Connection type / variants	CCS TYP 2 (AC / DC)		
Maximum charging capacity AC / DC	kW	22 / 104	
Maximum charging time AC ⁵⁾	0–100 %	h:min	6:00
Maximum charging time DC ⁵⁾	20–80 %	h:min	0:39
	5–90 %	h:min	1:16

POWERTRAIN

Climbing ability	20 %
------------------	------

CHASSIS

Front axle / rear axle	Leaf springs / E-axle		
Tyres	225/70 R 19.5		
Wheel	19.5 x 6.00 - 127		
Steering	Right-hand drive	Recirculating ball steering with power assist, tilting telescopic steering column with steering-wheel lock	
Brake	Service brake	Hydraulic with vacuum power assist, dual-circuit with load-dependent brake proportioning valve at rear wheels	
	Front / rear	Disc brake (355 x 42 mm)	
	Parking brake	Electromechanical brake caliper on rear disc brake	
Suspension	Front / rear	Semi-elliptic leaf springs with shock absorber and stabilizer	
Frame	Type	Ladder-type frame with reinforcements and crossmembers	
Electrical system	Low voltage batteries	Series 12 V (80 Ah) / optional 24 V (80 + 60 Ah)	

3) The specified weight includes both the battery(ies) with 325 kg each and the peripheral installations (cabling, temperature control, protection, etc.).

4) The range depends on various factors such as load, driving style, topography, ambient temperature or weather, battery age, vehicle equipment. The actual range may vary.

The given values for the range were tested with a box body, a load of 50% of the payload, an ambient temperature of 20 °C and an average battery age.

5) The charging time depends on various factors such as the charging capacity of the vehicle and charging station, the battery's state of charge, ambient and battery temperature.

The given values for the charging time were tested under optimum ambient temperature of 20 °C.

The illustrations may contain accessories and items of optional equipment which are not part of the standard specification. The data sheet may contain product types and support services not available in certain countries.