

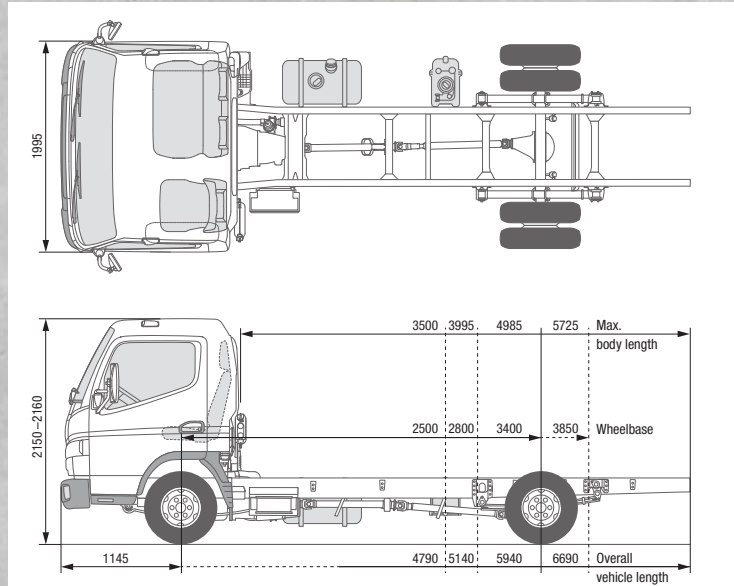

# CANTER 3C15 DUONIC® 2.0

## LHD



MODEL / VEHICLE TYPE		3C15			
Cab type / crew		Comfort, single cab / 3			
Model variant		46887211	46887311	46887511	46887711
FUSO model code		FEB01BL3SEUT	FEB01CL3SEUT	FEB01EL3SEUT	FEB01GL3SEUT
DIMENSIONS mm					
Wheelbase		2500	2800	3400	3850
Overall length		4790	5140	5940	6690
Cab length		1625			
Width overall		1995			
Cab width		1995			
Height overall		2160	2155	2155	2150
Track width	Front / rear	1665 / 1500			
Frame height (at end of frame)		755		750	
Ground clearance		165			
Cab to rear axle		1975	2275	2875	3325
Cab to end of frame		3120	3470	4270	5020
Max. body length**		3500	3995	4985	5725
Frame width		750			
Front overhang		1145			
Rear overhang		1145	1195	1395	1695
Front axle to front of body		625			
Recommended distance cab to body		100			
WEIGHTS kg					
Empty weight*		2025	2035	2065	2075
	Front* / rear*	1475 / 550	1505 / 530	1530 / 535	1545 / 530
Minimum vehicle weight		2355	2355	2355	2355
Gross vehicle weight / gross combination weight		3500 / 7000			
Axle loads	Front / rear	1900 / 2500			
Towed weight	Braked / unbraked	3500 / 750			
Chassis load bearing capacity		1475	1465	1435	1425
CALCULATED OUTPUT					
Max. speed	km/h	137			
Min. turning circle (m)	Kerb to kerb	8.6	9.4	11.2	12.4
	Wall to wall	10.0	11.0	12.6	14.0

\* including coolant, oil, 90% fuel, tyre sealant, tools and driver weighing 75 kg; \*\* calculated maximum value. Should be checked depending on the body installed and the particular application  
 Subject to change without notice. The information in this data sheet should be considered approximate. The illustrations may show accessories and special equipment not part of the standard specification. This data sheet may also contain models and support services not available in certain countries.



# CANTER 3C15 DUONIC® 2.0 LHD

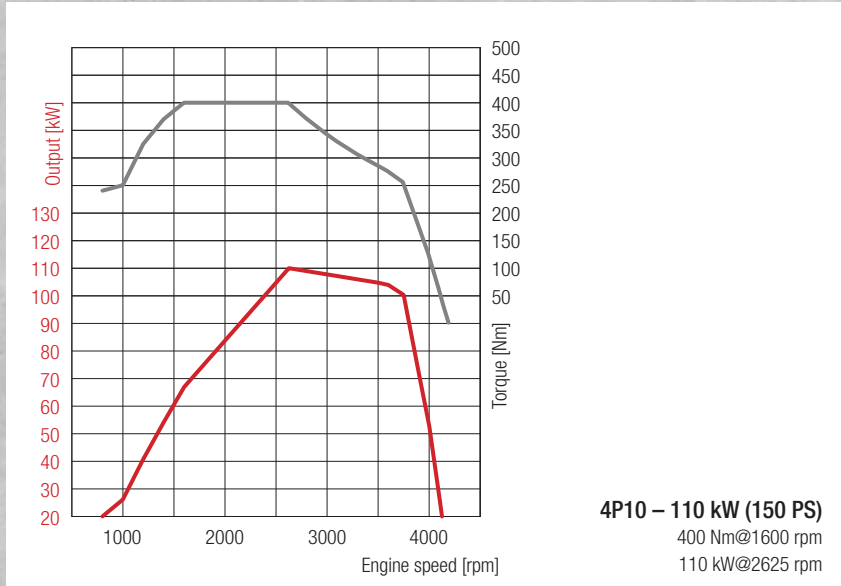

**4P10 – 110 kW (150 PS)**  
400 Nm@1600 rpm  
110 kW@2625 rpm

## ENGINE (Euro VI)

Type	Water-cooled four-stroke diesel engine with turbocharger, intercooler and direct injection		
No. of cylinders	4/in-line		
Capacity	2998 cm <sup>3</sup>		
Peak output	110 kW (150 hp) / 2625 rpm		
Rated torque	400 Nm / 1600 rpm		
Diesel particulate filter	Service life approx. 300,000 km		
Alternator	Alternating current 12V, 140A		
Exhaust gas aftertreatment	DPF + SCR		
PTO (optional)	Type	31 kW with flange	31 kW for directly connected pumps
	Torque at peak output [Nm]:	196 Nm	
	Gear ratios	1:0.655	1:0.651
	Engine speed at peak output	1500 rpm	

## POWERTRAIN

Transmission	Model	DUONIC® 2.0: Automated transmission with dual clutch, 6 forward speeds and 1 reverse gear
	Gear ratio	5.397 - 3.788 - 2.310 - 1.474 - 1.000 - 0.701 Rev. 5.397
Rear axle gear ratio	Ratio	4.111

## CHASSIS

Front axle / rear axle	Model	F100T / R015T
	Load-bearing capacity front/rear	1900 kg / 2500 kg
Tyres		195/75R16C 107/105 R
		Twin tyres at rear
Wheel		16 x 5 JK - 110
Steering		LHD
		Recirculating-ball steering with power assist, tilting telescopic steering column with steering-wheel lock
Brake	Service brake	Hydraulic with vacuum power assist, dual-circuit with load-dependent brake proportioning valve at rear wheels
	Front / rear	Disc brake (217 x 24)
	Parking brake	Mechanical expanding brake on drive shaft at rear of transmission
	Auxiliary brake	Exhaust brake (50 kW)
Suspension	Front / rear	Independent wheel suspension (coil spring) with shock absorber / semi-elliptic leaf spring with shock absorber and stabiliser
Frame	Type	Ladder-type frame with reinforcements and crossmembers
Fuel tank capacity		70 litres
Electrical system – batteries		12 Volt (100 AH - 760 A(EN))